

# IMSPECTOR *NIR and SWIR*

SPECIM ImSpectors designed for NIR (900 - 1700nm) and SWIR (1000 - 2500nm) wavelength ranges can be used to transform a NIR camera with an InGaAs sensor or SWIR camera with an MCT sensor into a line-scan spectral imaging device. ImSpectors provide easiest integration and highest optical performance for NIR and SWIR ranges on the market.

## Near infrared wavelength range

IMSPECTOR		N17E
Optical characteristics		
Spectral range	900 - 1700nm	
Dispersion	110nm/mm	
Spectral resolution *1	5nm (with 30µm slit)	
Image size	max. 7.6 (spectral) x 14.2 (spatial) mm	
Spatial resolution *1	rms spot radius < 15µm *1	
Aberrations	No astigmatism	
Bending of spectral lines across spatial axis	Smile < 5µm	
Bending of spatial lines across spectral axis	Keystone < 5µm	
Numerical aperture	F/2.0	
Slit width, default	30µm (50, 80 and 150µm on request)	
Slit length	14.2mm	
Optical input	Telecentric	
Efficiency	> 50%, independent of polarization	
Stray light	< 0.5% (halogen lamp, 1400nm long-pass filter)	
Mechanical characteristics		
Size, OEM	(W)60 x (H) 60 x (L) 220mm	
Weight	1500g	
Body, OEM	Anonized aluminium tube	
Lens and camera mount	Standard C-mount for lens	
	Standard C-or U-mount adapter for camera	
User adjustments	Image axis relative to detector rows, back focal length adjustable ± 1mm	
Environmental characteristics		
Storage	-20 ... +85 °C, non-condensing	
Operating	+5 ... +40°C, non-condensing	

\*1 System spectral and spatial resolutions also depend on the discrete imaging nature of detector and lens quality.

## Options, fore optics (NIR, SWIR)

- Fore optics: OLES15, OLES22.5, OLES30 and OLES56

More information about fore optics can be found from Hyperspectral fore lenses -data sheet.



ImSpector N17E spectrograph, side view



ImSpector N17E spectrograph, front view

## Short wave infrared wavelength range

IMSPECTOR		N25E
<b>Optical characteristics</b>		
Spectral range *1	1000 - 2500nm	
Dispersion	208nm/mm	
Spectral resolution *2	8nm	
Image size	max. 7.6 (spectral) x 14.2 (spatial) mm	
Spatial resolution *2	rms spot radius < 15µm,	
Aberrations	No astigmatism	
Bending of spectral lines across spatial axis	Smile < 5µm	
Bending of spatial lines across spectral axis	Keystone < 5µm	
Numerical aperture	F/2.0	
Slit width, default	30µm (50 and 80 µm on request)	
Slit length	14.2mm	
Optical input	Telecentric	
Efficiency	> 50%, independent of polarization	
<b>Mechanical characteristics</b>		
Size, OEM	(W) 60 x (H) x 60 x (L) 220cm	
Weight	1500g	
Body, OEM	Anonized aluminium tube	
Lens mount	Standard C-mount adapter	
Camera mount	Standard U-mount adapter	
User adjustments	Image axis relative to detector rows, back focal length adjustable ±1mm	
<b>Environmental characteristics</b>		
Storage	-20 ... +80 °C	
Operating	+5 ... +40 °C, non-condensing	

## Options, accessories (NIR, SWIR)

- Mechanical shutter
- Collection fiber optics
- Order blocking filter; OBF 1400 for N25E (rectangular, 18 x 18mm)
- Fiber optic diffuse irradiance sensor (FODIS) for light source monitoring

More information about fiber optics can be found from Multipoint spectrometers -data sheet.

\*1 Order blocking filter is available for mounting on the detector window.

\*2 System spectral and spatial resolutions also depend on the discrete imaging nature of detector and lens quality.

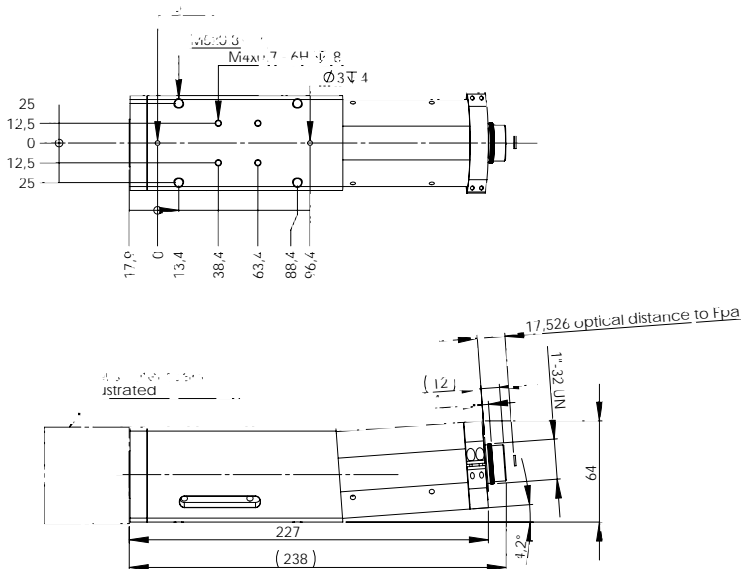

ImSpector N17E mechanical dimensions

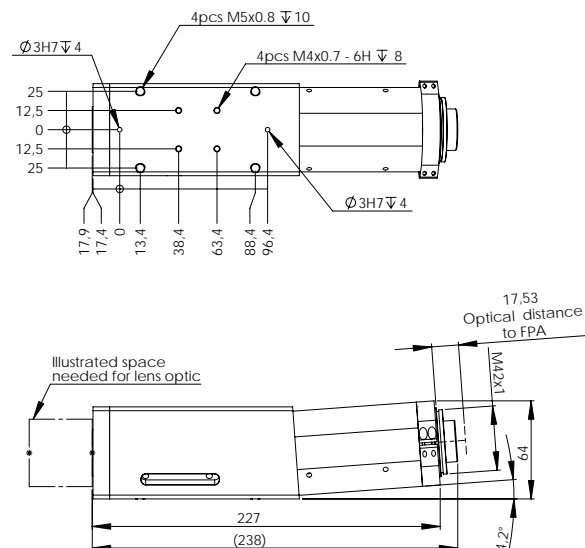

ImSpector N25E mechanical dimensions